



## 8155/8156/8155-2/8156-2 2048 BIT STATIC MOS RAM WITH I/O PORTS AND TIMER

- 256 Word x 8 Bits
- Single +5V Power Supply
- Completely Static Operation
- Internal Address Latch
- 2 Programmable 8 Bit I/O Ports
- 1 Programmable 6-Bit I/O Port
- Programmable 14-Bit Binary Counter/Timer
- Compatible with 8085A and 8088 CPU
- Multiplexed Address and Data Bus
- 40 Pin DIP

The 8155 and 8156 are RAM and I/O chips to be used in the 8085A and 8088 microprocessor systems. The RAM portion is designed with 2048 static cells organized as 256 x 8. They have a maximum access time of 400 ns to permit use with no wait states in 8085A CPU. The 8155-2 and 8156-2 have maximum access times of 330 ns for use with the 8085A-2 and the full speed 5 MHz 8088 CPU.

The I/O portion consists of three general purpose I/O ports. One of the three ports can be programmed to be status pins, thus allowing the other two ports to operate in handshake mode.

A 14-bit programmable counter/timer is also included on chip to provide either a square wave or terminal count pulse for the CPU system depending on timer mode.

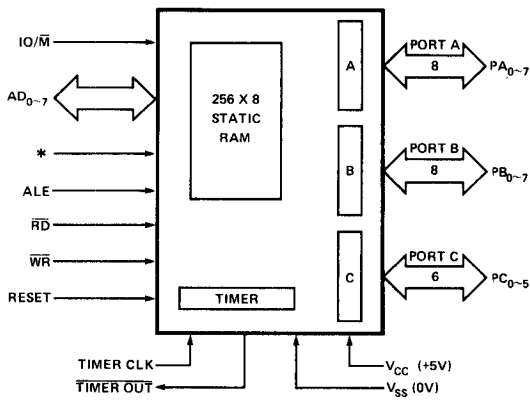

\*: 8155/8155-2 =  $\overline{CE}$ , 8156/8156-2 = CE

**Figure 1. Block Diagram**

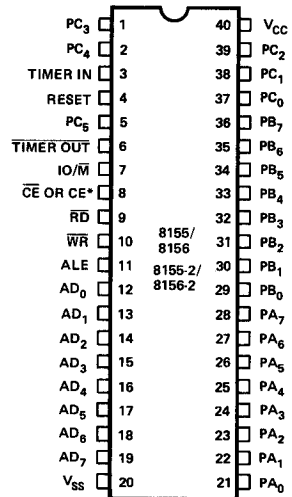

**Figure 2. Pin Configuration**

**Table 1. Pin Description**

Symbol	Type	Name and Function
RESET	I	<b>Reset:</b> Pulse provided by the 8085A to initialize the system (connect to 8085A RESET OUT). Input high on this line resets the chip and initializes the three I/O ports to input mode. The width of RESET pulse should typically be two 8085A clock cycle times.
AD <sub>0-7</sub>	I/O	<b>Address/Data:</b> 3-state Address/Data lines that interface with the CPU lower 8-bit Address/Data Bus. The 8-bit address is latched into the address latch inside the 8155/86 on the falling edge of ALE. The address can be either for the memory section or the I/O section depending on the IO/M input. The 8-bit data is either written into the chip or read from the chip, depending on the WR or RD input signal.
CE or $\overline{CE}$	I	<b>Chip Enable:</b> On the 8155, this pin is $\overline{CE}$ and is ACTIVE LOW. On the 8156, this pin is CE and is ACTIVE HIGH.
$\overline{RD}$	I	<b>Read Control:</b> Input low on this line with the Chip Enable active enables and AD <sub>0-7</sub> buffers. If IO/M pin is low, the RAM content will be read out to the AD bus. Otherwise the content of the selected I/O port or command/status registers will be read to the AD bus.
$\overline{WR}$	I	<b>Write Control:</b> Input low on this line with the Chip Enable active causes the data on the Address/Data bus to be written to the RAM or I/O ports and command/status register, depending on IO/M.
ALE	I	<b>Address Latch Enable:</b> This control signal latches both the address on the AD <sub>0-7</sub> lines and the state of the Chip Enable and IO/M into the chip at the falling edge of ALE.
IO/M	I	<b>I/O Memory:</b> Selects memory if low and I/O and command/status registers if high.
PA <sub>0-7</sub> (8)	I/O	<b>Port A:</b> These 8 pins are general purpose I/O pins. The in/out direction is selected by programming the command register.
PB <sub>0-7</sub> (8)	I/O	<b>Port B:</b> These 8 pins are general purpose I/O pins. The in/out direction is selected by programming the command register.
PC <sub>0-5</sub> (6)	I/O	<b>Port C:</b> These 6 pins can function as either input port, output port, or as control signals for PA and PB. Programming is done through the command register. When PC <sub>0-5</sub> are used as control signals, they will provide the following: PC <sub>0</sub> — A INTR (Port A Interrupt) PC <sub>1</sub> — A BF (Port A Buffer Full) PC <sub>2</sub> — A STB (Port A Strobe) PC <sub>3</sub> — B INTR (Port B Interrupt) PC <sub>4</sub> — B BF (Port B Buffer Full) PC <sub>5</sub> — B STB (Port B Strobe)
TIMER IN	I	<b>Timer Input:</b> Input to the counter-timer.
TIMER OUT	O	<b>Timer Output:</b> This output can be either a square wave or a pulse, depending on the timer mode.
V <sub>CC</sub>		<b>Voltage:</b> +5 volt supply.
V <sub>SS</sub>		<b>Ground:</b> Ground reference.

### FUNCTIONAL DESCRIPTION

The 8155/8156 contains the following:

- 2k Bit Static RAM organized as 256 x 8
- Two 8-bit I/O ports (PA & PB) and one 6-bit I/Oport (PC)
- 14-bit timer-counter

The  $\overline{IO/\overline{M}}$  (IO/Memory Select) pin selects either the five registers (Command, Status, PA<sub>0-7</sub>, PB<sub>0-7</sub>, PC<sub>0-5</sub>) or the memory (RAM) portion.

The 8-bit address on the Address/Data lines, Chip Enable input CE or  $\overline{CE}$ , and  $\overline{IO/\overline{M}}$  are all latched on-chip at the falling edge of ALE.

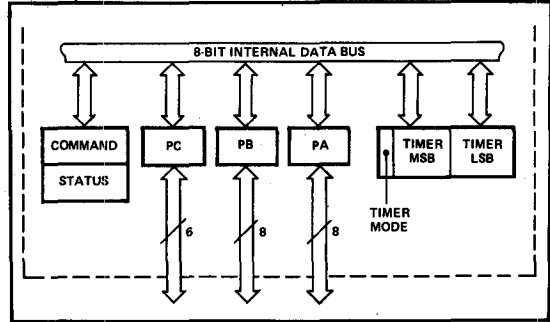
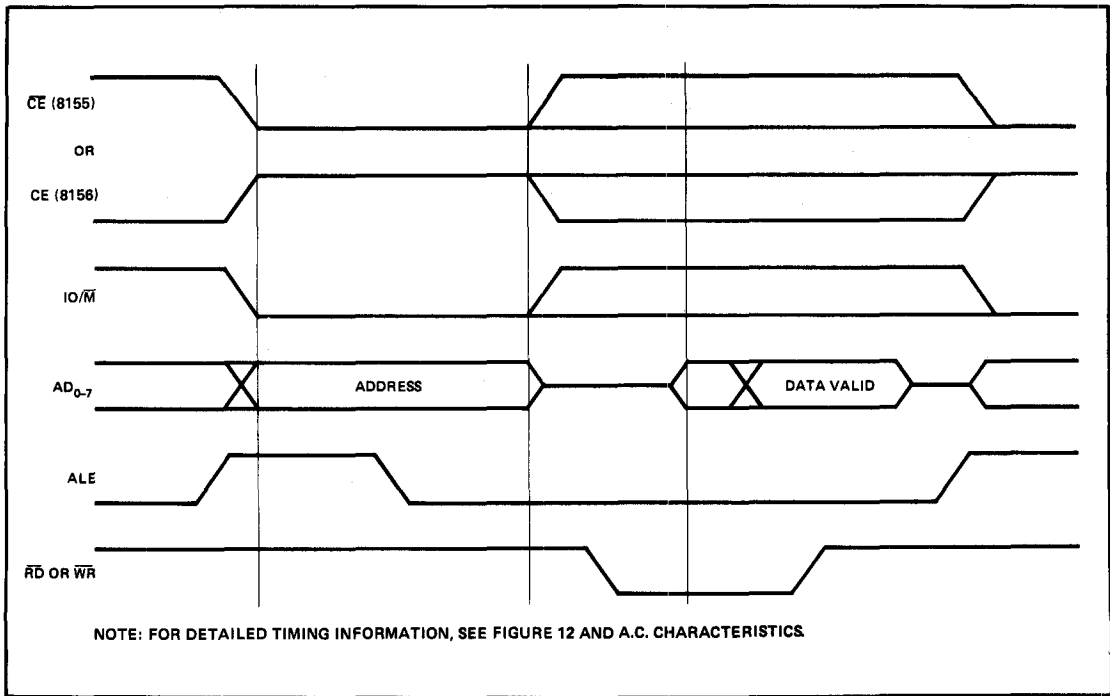

Figure 3. 8155/8156 Internal Registers



NOTE: FOR DETAILED TIMING INFORMATION, SEE FIGURE 12 AND A.C. CHARACTERISTICS.

Figure 4. 8155/8156 On-Board Memory Read/Write Cycle

## PROGRAMMING OF THE COMMAND REGISTER

The command register consists of eight latches. Four bits (0-3) define the mode of the ports, two bits (4-5) enable or disable the interrupt from port C when it acts as control port, and the last two bits (6-7) are for the timer.

The command register contents can be altered at any time by using the I/O address XXXXX000 during a WRITE operation with the Chip Enable active and  $IO/\overline{M} = 1$ . The meaning of each bit of the command byte is defined in Figure 5. The contents of the command register may never be read.

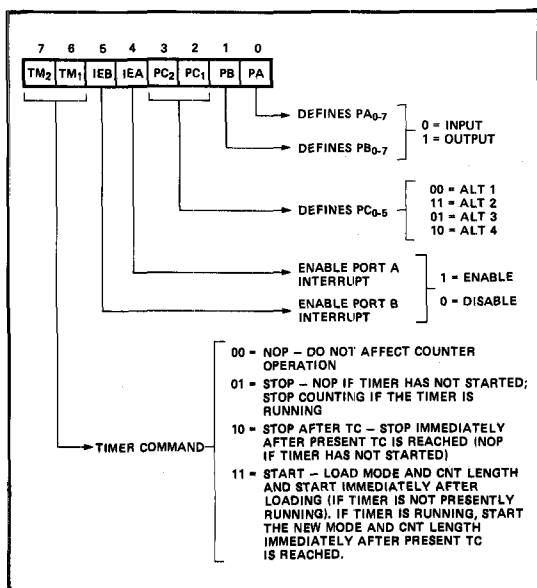

Figure 5. Command Register Bit Assignment

## READING THE STATUS REGISTER

The status register consists of seven latches, one for each bit; six (0-5) for the status of the ports and one (6) for the status of the timer.

The status of the timer and the I/O section can be polled by reading the Status Register (Address XXXXX000). Status word format is shown in Figure 6. Note that you may never write to the status register since the command register shares the same I/O address and the command register is selected when a write to that address is issued.

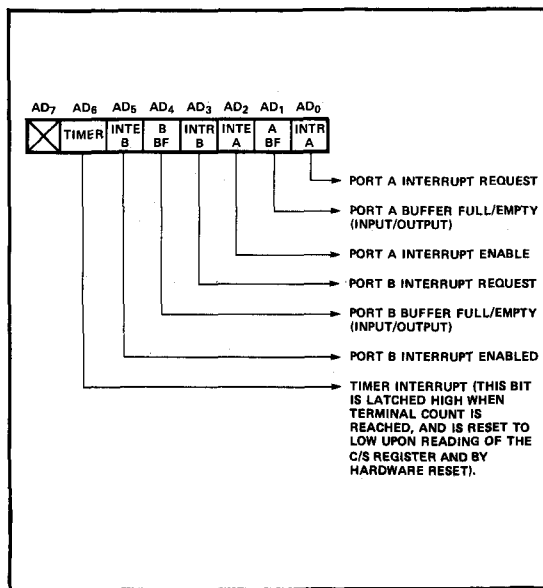

Figure 6. Status Register Bit Assignment

### INPUT/OUTPUT SECTION

The I/O section of the 8155/8156 consists of five registers: (See Figure 7.)

- **Command/Status Register (C/S)** — Both registers are assigned the address XXXXX000. The C/S address serves the dual purpose.

When the C/S registers are selected during WRITE operation, a command is written into the command register. The contents of this register are *not* accessible through the pins.

When the C/S (XXXXX000) is selected during a READ operation, the status information of the I/O ports and the timer becomes available on the AD<sub>0-7</sub> lines.

- **PA Register** — This register can be programmed to be either input or output ports depending on the status of the contents of the C/S Register. Also depending on the command, this port can operate in either the basic mode or the strobed mode (See timing diagram). The I/O pins assigned in relation to this register are PA<sub>0-7</sub>. The address of this register is XXXXX001.
- **PB Register** — This register functions the same as PA Register. The I/O pins assigned are PB<sub>0-7</sub>. The address of this register is XXXXX010.
- **PC Register** — This register has the address XXXXX011 and contains only 6 bits. The 6 bits can be programmed to be either input ports, output ports or as control signals for PA and PB by properly programming the AD<sub>2</sub> and AD<sub>3</sub> bits of the C/S register.

When PC<sub>0-5</sub> is used as a control port, 3 bits are assigned for Port A and 3 for Port B. The first bit is an interrupt that the 8155 sends out. The second is an output signal indicating whether the buffer is full or empty, and the third is an input pin to accept a strobe for the strobed input mode. (See Table 2.)

When the 'C' port is programmed to either ALT3 or ALT4, the control signals for PA and PB are initialized as follows:

CONTROL	INPUT MODE	OUTPUT MODE
BF	Low	Low
INTR	Low	High
STB	Input Control	Input Control

I/O ADDRESS†								SELECTION	
A7	A6	A5	A4	A3	A2	A1	A0		
X	X	X	X	X	0	0	0	Internal Command/Status Register	
X	X	X	X	X	0	0	1	General Purpose I/O Port A	
X	X	X	X	X	0	1	0	General Purpose I/O Port B	
X	X	X	X	X	0	1	1	Port C — General Purpose I/O or Control	
X	X	X	X	X	1	0	0	Low-Order 8 bits of Timer Count	
X	X	X	X	X	1	0	1	High 6 bits of Timer Count and 2 bits of Timer Mode	

X: Don't Care.  
†: I/O Address must be qualified by CE = 1 (8156) or  $\overline{CE}$  = 0 (8155) and  $\overline{IO/\overline{M}}$  = 1 in order to select the appropriate register.

Figure 7. I/O Port and Timer Addressing Scheme

Figure 8 shows how I/O PORTS A and B are structured within the 8155 and 8156:

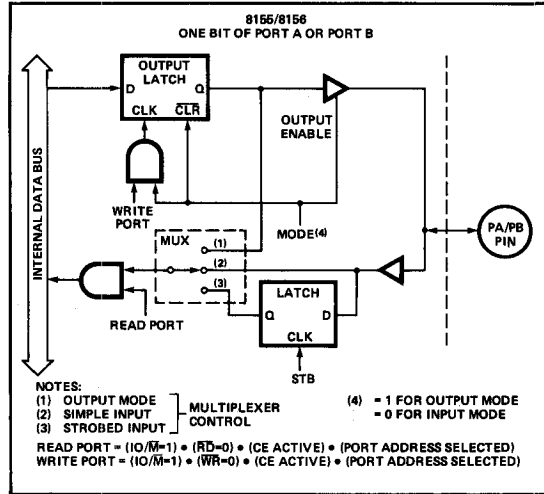

Figure 8. 8155/8156 Port Functions

**Table 2. Port Control Assignment**

Pin	ALT 1	ALT 2	ALT 3	ALT 4
PC0	Input Port	Output Port	A INTR (Port A Interrupt)	A INTR (Port A Interrupt)
PC1	Input Port	Output Port	A BF (Port A Buffer Full)	A BF (Port A Buffer Full)
PC2	Input Port	Output Port	A STB (Port A Strobe)	A STB (Port A Strobe)
PC3	Input Port	Output Port	Output Port	B INTR (Port B Interrupt)
PC4	Input Port	Output Port	Output Port	B BF (Port B Buffer Full)
PC5	Input Port	Output Port	Output Port	B STB (Port B Strobe)

Note in the diagram that when the I/O ports are programmed to be output ports, the contents of the output ports can still be read by a READ operation when appropriately addressed.

The outputs of the 8155/8156 are "glitch-free" meaning that you can write a "1" to a bit position that was previously "1" and the level at the output pin will not change.

Note also that the output latch is cleared when the port enters the input mode. The output latch cannot be loaded by writing to the port if the port is in the input mode. The result is that each time a port mode is changed from input to output, the output pins will go low. When the 8155/56 is RESET, the output latches are all cleared and all 3 ports enter the input mode.

When in the ALT 1 or ALT 2 modes, the bits of PORT C are structured like the diagram above in the simple input or output mode, respectively.

Reading from an input port with nothing connected to the pins will provide unpredictable results.

Figure 9 shows how the 8155/8156 I/O ports might be configured in a typical MCS-85 system.

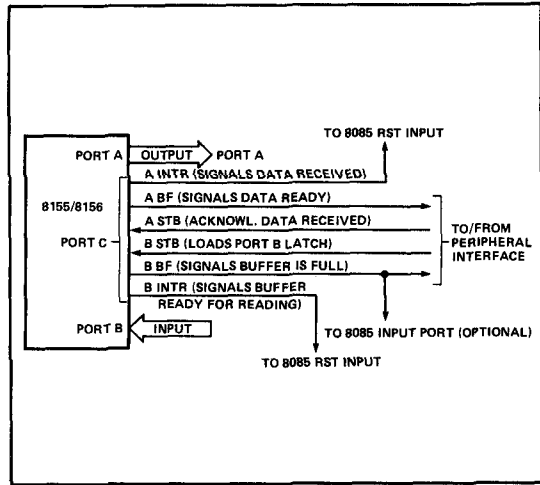

**Figure 9. Example: Command Register = 00111001**

## TIMER SECTION

The timer is a 14-bit down-counter that counts the TIMER IN pulses and provides either a square wave or pulse when terminal count (TC) is reached.

The timer has the I/O address XXXXX100 for the low order byte of the register and the I/O address XXXXX101 for the high order byte of the register. (See Figure 7.)

To program the timer, the COUNT LENGTH REG is loaded first, one byte at a time, by selecting the timer addresses. Bits 0-13 of the high order count register will specify the length of the next count and bits 14-15 of the high order register will specify the timer output mode (see Figure 10). The value loaded into the count length register can have any value from 2H through 3FFH in Bits 0-13.

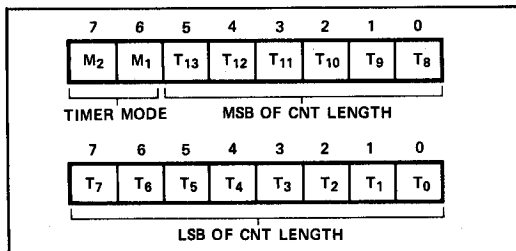

Figure 10. Timer Format

There are four modes to choose from: M2 and M1 define the timer mode, as shown in Figure 11.

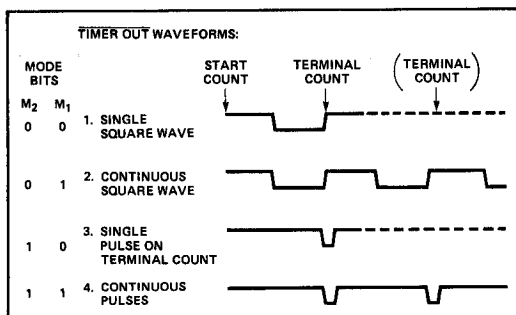

Figure 11. Timer Modes

Bits 6-7 (TM<sub>2</sub> and TM<sub>1</sub>) of command register contents are used to start and stop the counter. There are four commands to choose from:

TM <sub>2</sub>	TM <sub>1</sub>	
0	0	NOP — Do not affect counter operation.
0	1	STOP — NOP if timer has not started; stop counting if the timer is running.
1	0	STOP AFTER TC — Stop immediately after present TC is reached (NOP if timer has not started)
1	1	START — Load mode and CNT length and start immediately after loading (if timer is not presently running). If timer is running, start the new mode and CNT length immediately after present TC is reached.

Note that while the counter is counting, you may load a new count and mode into the count length registers. Before the new count and mode will be used by the counter, you must issue a START command to the counter. This applies even though you may only want to change the count and use the previous mode.

In case of an odd-numbered count, the first half-cycle of the squarewave output, which is high, is one count longer than the second (low) half-cycle, as shown in Figure 12.

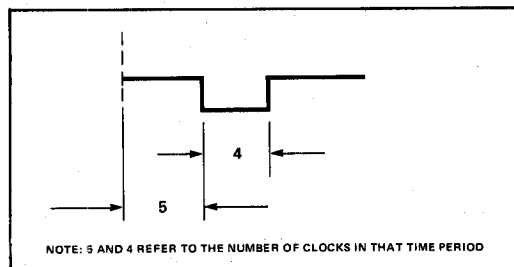

Figure 12. Asymmetrical Square-Wave Output Resulting from Count of 9

The counter in the 8155 is not initialized to any particular mode or count when hardware RESET occurs, but RESET does stop the counting. Therefore, counting cannot begin following RESET until a START command is issued via the C/S register.

Please note that the timer circuit on the 8155/8156 chip is designed to be a square-wave timer, not an event counter. To achieve this, it counts down by twos twice in completing one cycle. Thus, its registers do not contain values directly representing the number of TIMER IN pulses received. You cannot load an initial value of 1 into the count register and cause the timer to operate, as its terminal count value is 10 (binary) or 2 (decimal). (For the detection of single pulses, it is suggested that one of the hardware interrupt pins on the 8085A be used.) After the timer has started counting down, the values residing in the count registers can be used to calculate the actual number of TIMER IN pulses required to complete the timer cycle if desired. To obtain the remaining count, perform the following operations in order:

1. Stop the count
2. Read in the 16-bit value from the count length registers
3. Reset the upper two mode bits
4. Reset the carry and rotate right one position all 16 bits through carry
5. If carry is set, add 1/2 of the full original count (1/2 full count — 1 if full count is odd).

Note: If you started with an odd count and you read the count length register before the third count pulse occurs, you will not be able to discern whether one or two counts has occurred. Regardless of this, the 8155/56 always counts out the right number of pulses in generating the TIMER OUT waveforms.

## EXAMPLE PROGRAM

Following is an actual sequence of program steps that adjusts the 8155/56 count register contents to obtain the count, extracted from Intel® Application Note AP38. "Application Techniques for the Intel 8085A Bus." First store the value of the full original count in register HL of the 8085A. Then stop the count to avoid getting an incorrect count value. Then sample the timer-counter, storing the lower-order byte of the current count register in register C and the higher-order count byte in register B. Then, call the following 8080A/8085A subroutine:

ADJUST, 78	MOV A,B	;Load accumulator with upper half ; of count.
E63F	ANI 3F	;Reset upper 2 bits and clear carry.
1F	RAR	;Rotate right through carry.
47	MOV B,A	;Store shifted value back in B.
79	MOV A,C	;Load accumulator with lower half.
1F	RAR	;Rotate right through carry.
4F	MOV C,A	;Store lower byte in C.
D0	RNC	;If in 2nd half of count, return. ;If in 1st half, go on.
3F	CMC	;Clear carry.
7C	MOV A,H	;Divide full count by 2. (If HL ;is odd, disregard remainder.)
1F	RAR	
67	MOV H,A	
7D	MOV A,L	
1F	RAR	
6F	MOV L,A	
09	DAD B	;Double-precision add HL and BC.
44	MOV B,H	;Store results back in BC.
4D	MOV C,L	
C9	RET	;Return.

After executing the subroutine, BC will contain the remaining count in the current count cycle.



### 8085A MINIMUM SYSTEM CONFIGURATION

Figure 13a shows a minimum system using three chips, containing:

- 256 Bytes RAM
- 2K Bytes ROM
- 38 I/O Pins
- 1 Interval Timer
- 4 Interrupt Levels

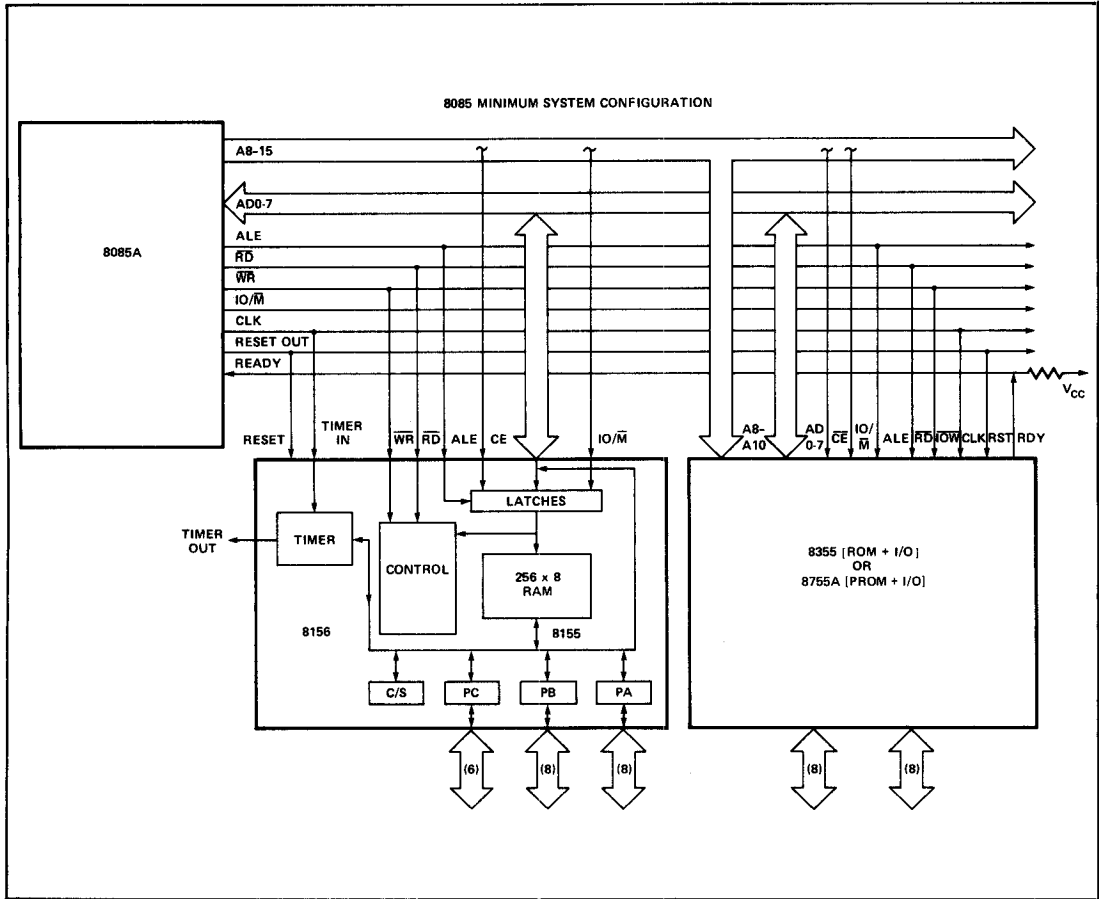

Figure 13a. 8085A Minimum System Configuration (Memory Mapped I/O)

8088 FIVE CHIP SYSTEM

Figure 13b shows a five chip system containing:

- 1.25K Bytes RAM
- 2K Bytes ROM
- 38 I/O Pins
- 1 Interval Timer
- 2 Interrupt Levels

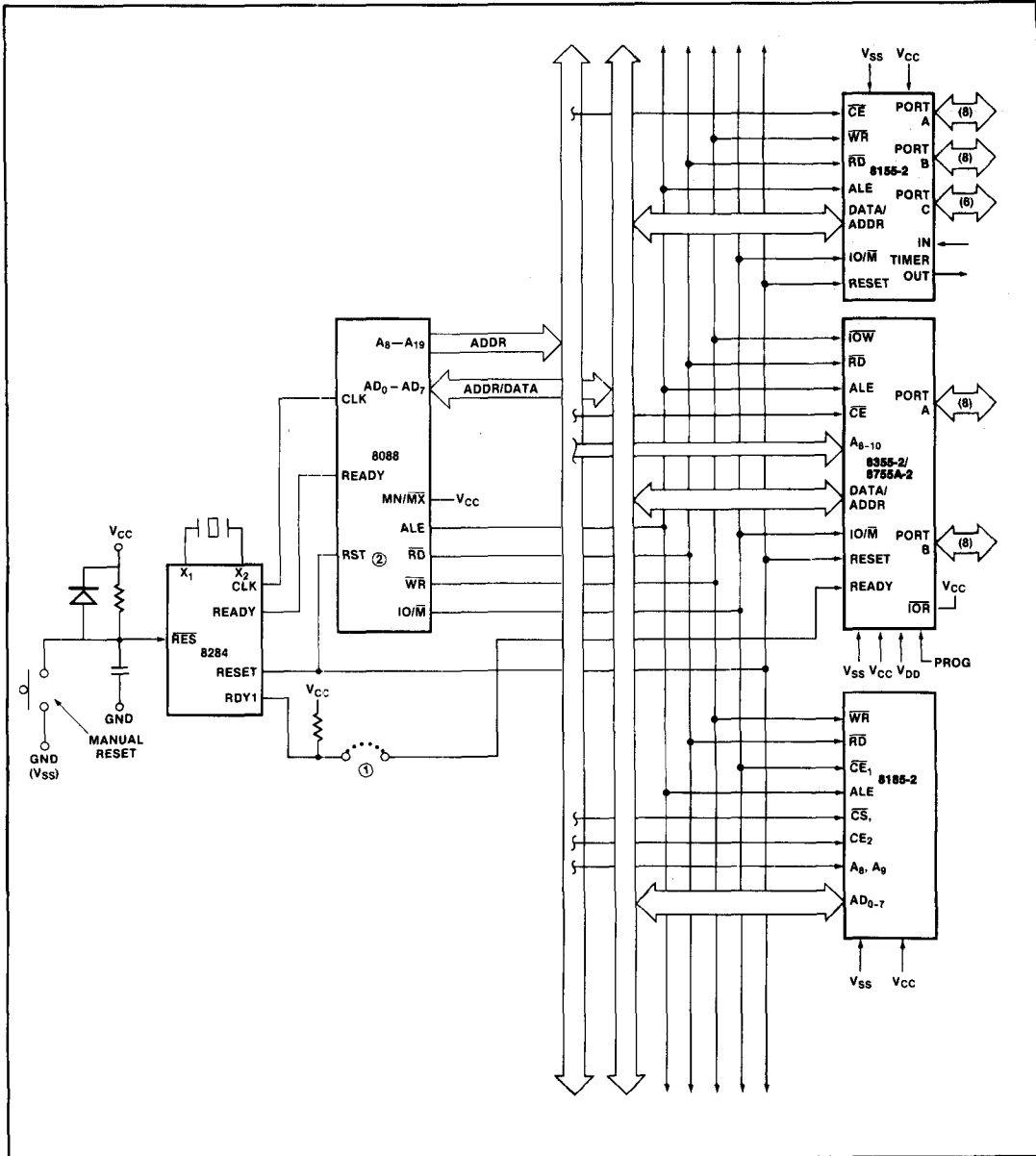

Figure 13b. 8088 Five Chip System Configuration

**ABSOLUTE MAXIMUM RATINGS\***

Temperature Under Bias ..... 0°C to +70°C  
 Storage Temperature ..... -65°C to +150°C  
 Voltage on Any Pin  
     With Respect to Ground ..... -0.5V to +7V  
 Power Dissipation ..... 1.5W

*\*NOTICE: Stresses above those listed under "Absolute Maximum Ratings" may cause permanent damage to the device. This is a stress rating only and functional operation of the device at these or any other conditions above those indicated in the operational sections of this specification is not implied. Exposure to absolute maximum rating conditions for extended periods may affect device reliability.*

**D.C. CHARACTERISTICS** ( $T_A = 0^\circ\text{C to } 70^\circ\text{C}; V_{CC} = 5\text{V} \pm 5\%$ )

SYMBOL	PARAMETER	MIN.	MAX.	UNITS	TEST CONDITIONS
V <sub>IL</sub>	Input Low Voltage	-0.5	0.8	V	
V <sub>IH</sub>	Input High Voltage	2.0	V <sub>CC</sub> +0.5	V	
V <sub>OL</sub>	Output Low Voltage		0.45	V	I <sub>OL</sub> = 2mA
V <sub>OH</sub>	Output High Voltage	2.4		V	I <sub>OH</sub> = -400µA
I <sub>IL</sub>	Input Leakage		±10	µA	0V ≤ V <sub>IN</sub> ≤ V <sub>CC</sub>
I <sub>LO</sub>	Output Leakage Current		± 10	µA	0.45V ≤ V <sub>OUT</sub> ≤ V <sub>CC</sub>
I <sub>CC</sub>	V <sub>CC</sub> Supply Current		180	mA	
I <sub>IL</sub> (CE)	Chip Enable Leakage				
	8155		+100	µA	0V ≤ V <sub>IN</sub> ≤ V <sub>CC</sub>
	8156		-100	µA	

**A.C. CHARACTERISTICS** ( $T_A = 0^\circ\text{C}$  to  $70^\circ\text{C}$ ;  $V_{CC} = 5\text{V} \pm 5\%$ )

SYMBOL	PARAMETER	8155/8156		8155-2/8156-2		UNITS
		MIN.	MAX.	MIN.	MAX.	
$t_{AL}$	Address to Latch Set Up Time	50		30		ns
$t_{LA}$	Address Hold Time after Latch	80		30		ns
$t_{LC}$	Latch to READ/WRITE Control	100		40		ns
$t_{RD}$	Valid Data Out Delay from READ Control		170		140	ns
$t_{AD}$	Address Stable to Data Out Valid		400		330	ns
$t_{LL}$	Latch Enable Width	100		70		ns
$t_{RDF}$	Data Bus Float After READ	0	100	0	80	ns
$t_{CL}$	READ/WRITE Control to Latch Enable	20		10		ns
$t_{CC}$	READ/WRITE Control Width	250		200		ns
$t_{DW}$	Data In to WRITE Set Up Time	150		100		ns
$t_{WD}$	Data In Hold Time After WRITE	0		0		ns
$t_{RV}$	Recovery Time Between Controls	300		200		ns
$t_{WP}$	WRITE to Port Output		400		300	ns
$t_{PR}$	Port Input Setup Time	70		50		ns
$t_{RP}$	Port Input Hold Time	50		10		ns
$t_{SBF}$	Strobe to Buffer Full		400		300	ns
$t_{SS}$	Strobe Width	200		150		ns
$t_{RBE}$	READ to Buffer Empty		400		300	ns
$t_{SI}$	Strobe to INTR On		400		300	ns
$t_{RDI}$	READ to INTR Off		400		300	ns
$t_{PSS}$	Port Setup Time to Strobe Strobe	50		0		ns
$t_{PHS}$	Port Hold Time After Strobe	120		100		ns
$t_{SBE}$	Strobe to Buffer Empty		400		300	ns
$t_{WBF}$	WRITE to Buffer Full		400		300	ns
$t_{WI}$	WRITE to INTR Off		400		300	ns
$t_{TL}$	TIMER-IN to $\overline{\text{TIMER-OUT}}$ Low		400		300	ns
$t_{TH}$	TIMER-IN to $\overline{\text{TIMER-OUT}}$ High		400		300	ns
$t_{RDE}$	Data Bus Enable from READ Control	10		10		ns
$t_1$	TIMER-IN Low Time	80		40		ns
$t_2$	TIMER-IN High Time	120		70		ns

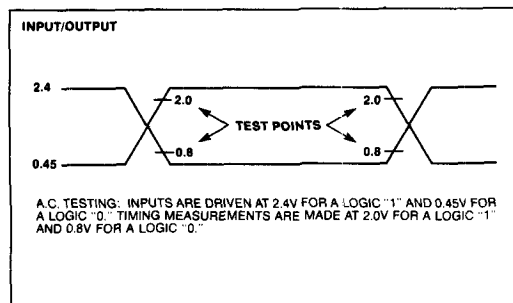
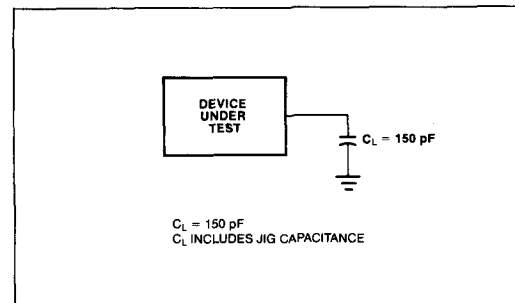
**A.C. TESTING INPUT, OUTPUT WAVEFORM**

**A.C. TESTING LOAD CIRCUIT**

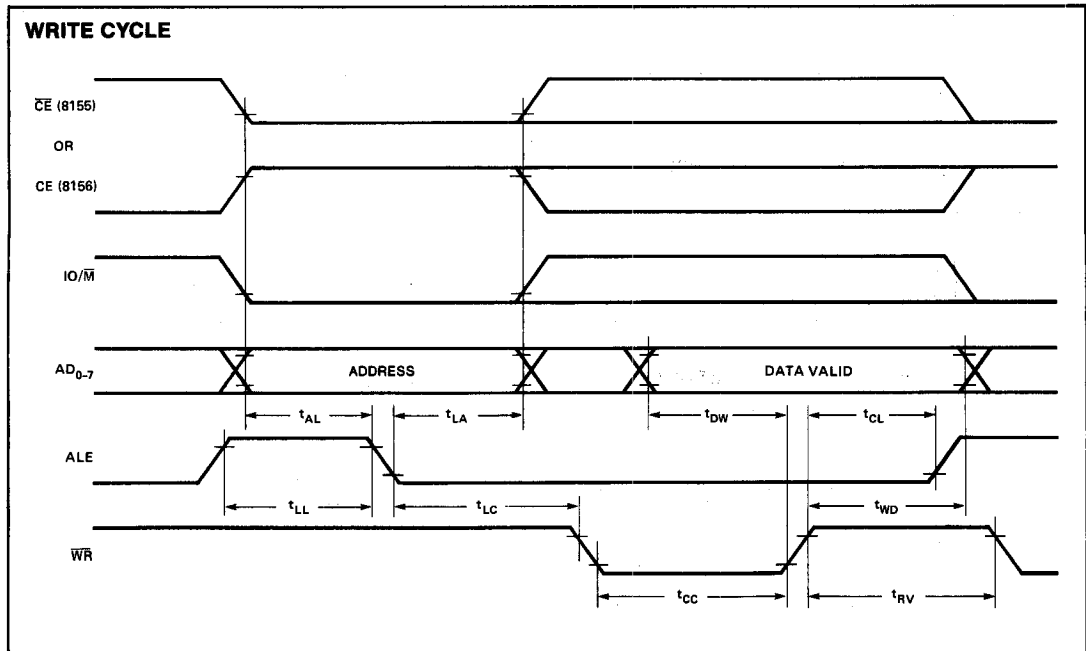
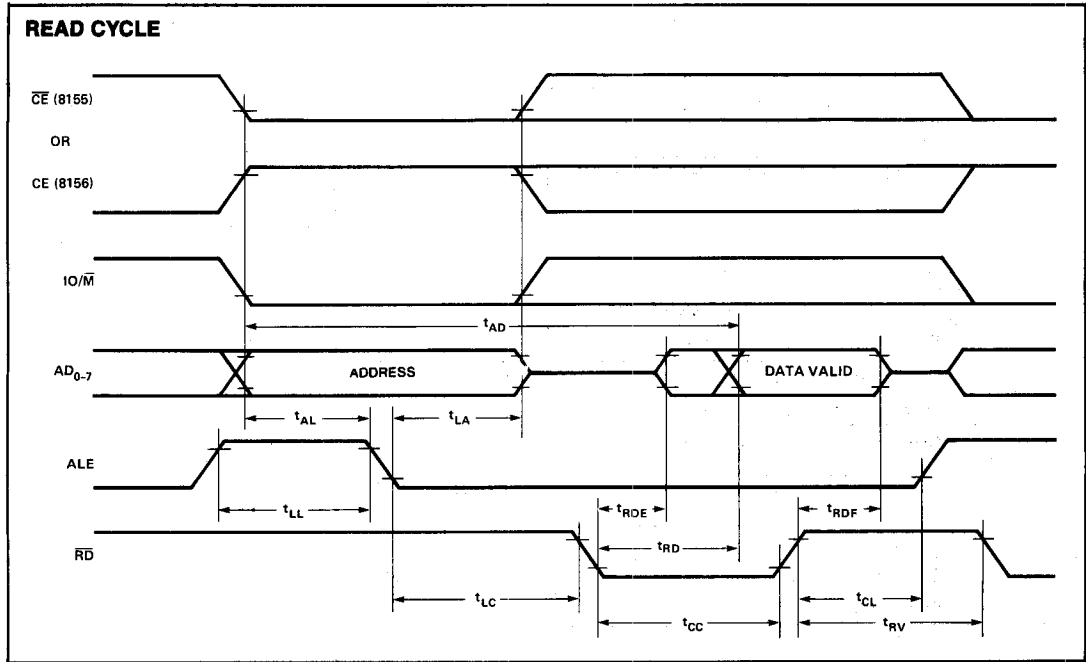
WAVEFORMS

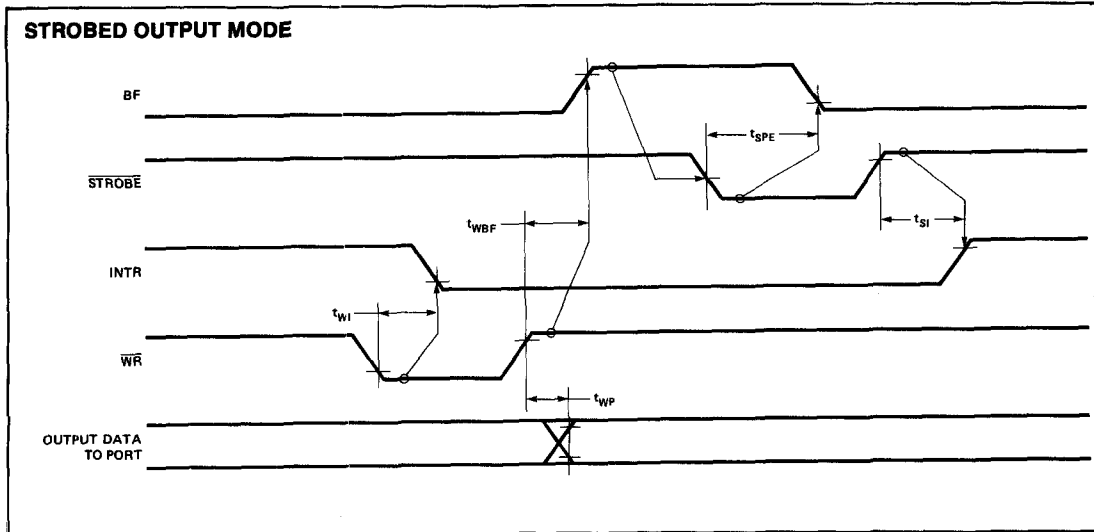
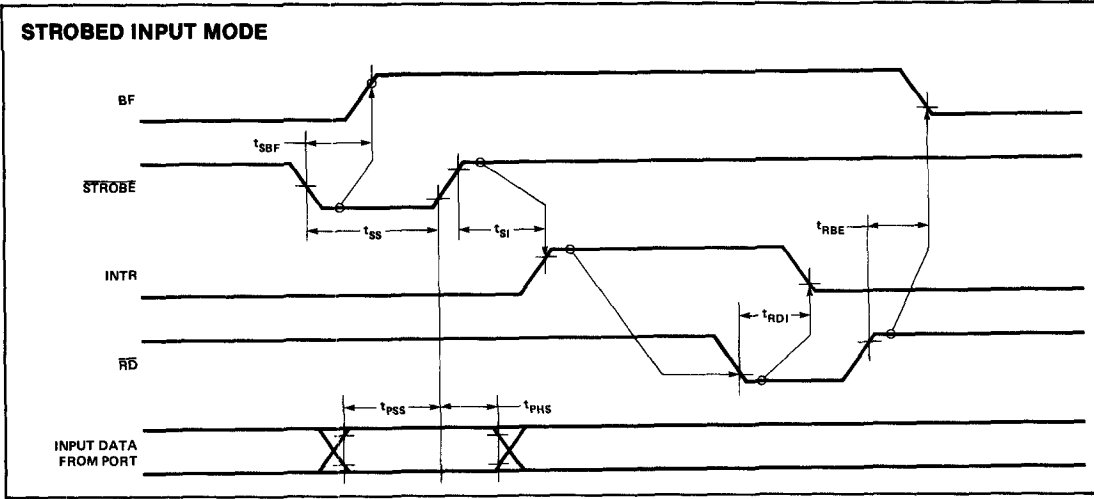

WAVEFORMS (Continued)



WAVEFORMS (Continued)

